

CORNELL

Counter Doors with Integral Frame and Sill

Factory Assembled = Fast Installation = Savings

Other manufacturer's units have frames that ship in several pieces and require a full installation of the shutter unit and individual piece installation of the frame sections. Cornell's Labeled and Non-labeled Package Units are **factory-welded and fully assembled** for a seamless, custom, built-in look. In addition to their pleasing aesthetics and durability, their single piece construction makes them fast and easy to install, saving time and money for contractors and building owners.

Mounting Options To Suit Your Application

- **Between jamb units** (as seen in photos) have the coil mounted within the opening with minimal projection beyond the wall. A **face of wall mounted coil option** is available with non-fire rated units only.
- **Slip-in units** may be set into finished walls, eliminating the need to coordinate unit installation while constructing the wall. Trim is provided for the unfinished side of the unit.
- **Built-in units** wrap around and trim the wall on both sides when installed while the wall is being constructed.

Sill Options

- **Standard sills** of 14 gauge, 300 series, #4 finish stainless steel add to the seamless, custom look.
- **Plastic laminate** labeled and non-labeled sills are also available. Finish selections are available from a full range of Wilsonart, Nevamar or Formica plastic laminates.
- Choose the **no sill option** when the seamless look of a package unit is desired, but a countertop already exists or will be provided by another trade.



Counter Doors with Frame and Sill

Model ESC20

- Built to order to fit specific dimensions up to 11'-7" wide and 4'-10" high.
- Use in masonry or drywall openings from 4" to 13" thick.
- Solid curtains and ScreenGard™ perforated see-through curtains are available.
- Both push-up and hand crank designs are offered.

UL Labeled Counter Fire Doors with Frame & Sill

Model ERC20

- UL 1 1/2, 1 or 3/4 hour label for fire protection.
- Built to order to fit specific dimensions up to 10'-0" wide and 4'-9" high.
- For use in rated walls, masonry or drywall with thickness ranging from 4 1/2" to 12" thick.
- Manual push-up operation.

Practical Design Applications

Service window openings in:

- Cafeterias
- Healthcare Facilities
- Educational Facilities
- Hospitality / Public Space

Benefits

- Fully assembled at the factory.
- Clean, custom appearance with no exposed edges.
- No field assembly makes for quick and easy installation.
- Slip-in units are ready to be set into existing walls, eliminating the need to coordinate installation during wall construction.
- Built-in units wrap around both sides of wall opening. Installation is done while wall is under construction.
- 14 gauge stainless steel sills are provided as standard.
- Units are built to exact opening size requirements.

Available Options

- Smoke gasketing
- Graphics for curtain or hood
- Cylinder locking device
- Non-labeled or Labeled laminate sills
- No sills
- Slip-in unit trim for coil head area

Integral Frame Unit Components

Brackets

Reinforced steel plates that bolt to jamb assembly and support counterbalance shaft and curtain.

Standard Material & Finish:

stainless steel with #4 finish or powder coated steel

Trim

#16 gauge bent steel jamb trim angles for slip-in units located opposite of finished side of opening. Head trim piece optional.

Standard Material & Finish:

stainless steel with #4 finish or powder coated steel

Frames

#16 gauge integral welded steel head and jambs. Guide groove is incorporated into jamb design.

Standard Material & Finish:

stainless steel with #4 finish or powder coated steel

Sills

Integral sill is formed of 14 gauge 300 series stainless steel with #4 finish.

Optional Material & Finish:

plastic laminate covered countertops, finish selected by customer

Counterbalance Shaft

3" diameter outer shaft and 5/8" inner shaft.

This assembly supports the curtain and contains counterbalance torsion springs for assisting operation.

Standard Material & Finish:

steel

Hood & Fascia

#16 gauge protective and aesthetic metal enclosure for the curtain that provides weather resistance at the head of the unit and keeps the brackets rigid.

Standard Material & Finish:

stainless steel with #4 finish or powder coated steel

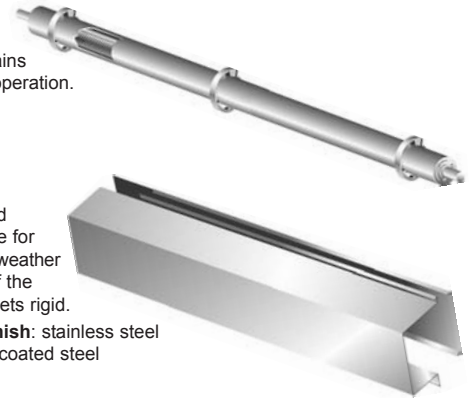

Curtain

Interlocking roll formed flat-faced 1-1/2" high slats with endlocks riveted to ends of alternate slats to maintain curtain alignment and prevent wear.

Standard Material & Finish:

stainless steel with #4 finish, galvanized steel with exclusive GalvaNex™ finish in light gray or aluminum with clear or color anodized finish (non-fire rated only)

Bottom Bar

Reinforcing member attached to the bottom of the curtain. Equipped with vinyl astragal / weather seal to cushion the contact point on the counter. Includes locking mechanisms.

Standard Material & Finish:

aluminum with clear or color anodized finish (non-fire rated only), stainless steel with #4 finish, or powder coated steel

Mounting & Clearances

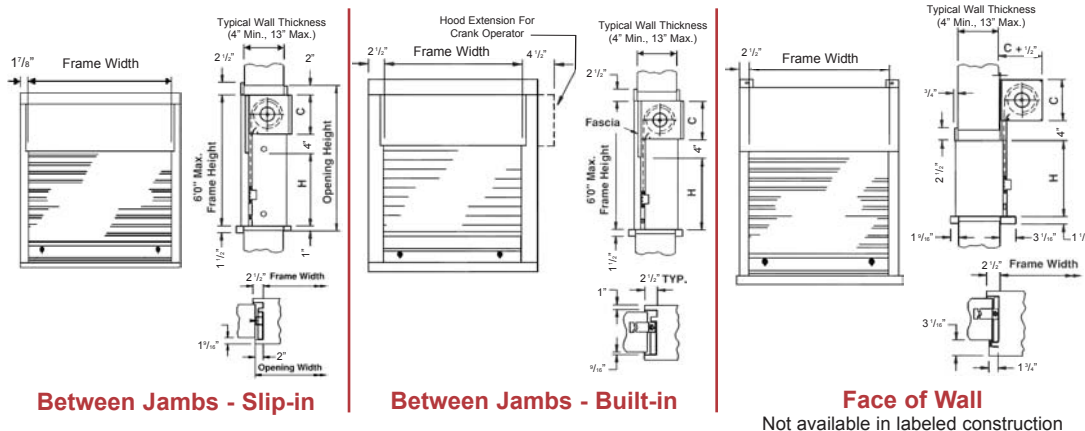

CORNELL
SAFE AND SECURE

An ISO 9001:2000 Registered Company

Crestwood Industrial Park
Mountaintop, PA 18707

TEL 800.233.8366

FAX 800.526.0841

Engineering Design Services:
Ext. 551

Website: www.cornelliron.com

Email: cornell@cornelliron.com

Non-labeled units shown. Labeled units are similar, but have wider frames.
Consult factory whenever dimensions are critical.